



UpSwell 2020 Products, Services, & Pricing

6 X 11 FLAT POSTCARD (PC)

Flat Postcards | Jumbo Postcards



POPULAR USES / BENEFITS

- Large – Stands Out in the Mailbox
- No Envelope to Open
- Personalization
- Customizable
- Generates Awareness
- Announcing Events & New Products/Services
- Promoting Special Offers

Product Specs

- **Size:** 6" x 11" flat
- **Layout:** Horizontal or vertical (your choice)
- **Color:** Full color on both sides
- **Paper:** 100 lb. gloss cover stock
- **Add a 1" Round Scratch-Off:** Additional \$0.01/piece for each scratch-off

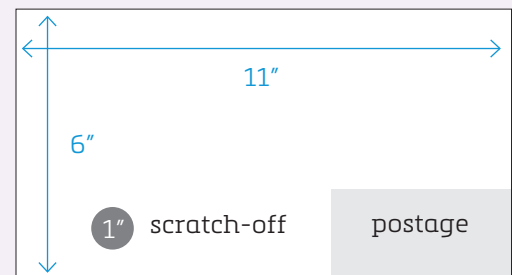

Product	List Type	Minimum Quantity	Cost
6x11 Postcard	Saturation	3,000	\$0.39
6x11 Postcard	Specialty List	500	\$0.53
6x11 Postcard with scratch off	Saturation	3,000	\$0.40

8 X 11 BI-FOLD TABBED SELF MAILER (BF)



Half-Fold Brochure | Brochures

POPULAR USES / BENEFITS

- Large – Stands Out in the Mailbox
- No Envelope to Open
- Customizable
- Personalization
- Maximum Space for More Photos, Coupons, Text, etc.
- Great Way to Educate Prospects and Customers
- Great for Showcasing Product Specs

Product Specs

- **Size:** 8" x 11" folded
- **Layout:** Horizontal or vertical (your choice)
- **Color:** Full color on both sides
- **Paper:** 100 lb. gloss cover stock
- **Add a 1" Round Scratch-Off:** Additional \$0.01/piece for each scratch-off

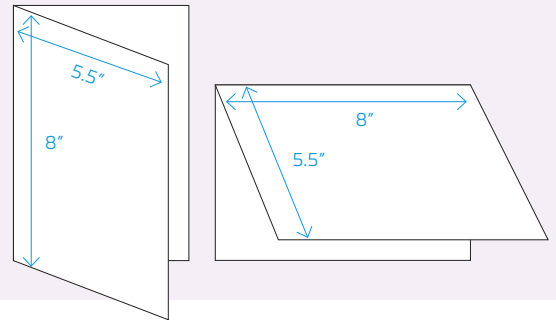

Product	List Type	Minimum Quantity	Cost
8x11 Bifold	Saturation	3,000	\$0.46
8x11 Bifold	Specialty List	3,000	\$0.58

First Class Postage: Add .25 per piece to convert from Standard Mail Postage (Marketing Mail) To First Class Presorted Postage. First Class Postage shortens delivery time by 3 to 5 business days. Note that it also requires special permit and production notes when processing.

Notes: Quantities > 2,500 add \$90 trucking fee (each print run includes 5 unaddressed samples).

10.5 X 17 TRIFOLD TABBED SELF MAILER (TF)

Tri-Fold Brochure | Newsletters



POPULAR USES / BENEFITS

- Large – Stands Out in the Mailbox
- No Envelope to Open (Tabbed)
- Customizable
- Personalization
- Great Way to Educate Prospects and Customers
- Great for Showcasing Product Specs

Product Specs

- **Size:** 10.5" x 17" trifold
- **Layout:** Horizontal or vertical (your choice)
- **Color:** Full color on both sides
- **Paper:** 100 lb. gloss text stock
- **Add a 1" Round Scratch-Off:** Additional \$0.01/piece for each scratch-off

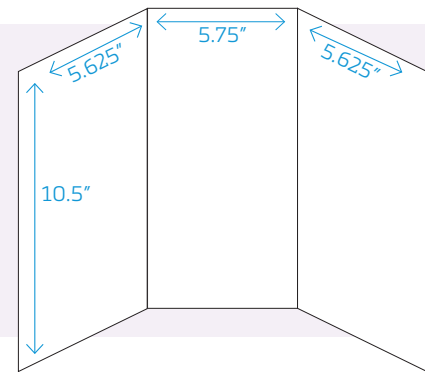

Product	List Type	Minimum Quantity	Cost
10.5x17 Trifold	Saturation	3,000	\$0.52
10.5x17 Trifold	Specialty List	3,000	\$0.63

First Class Postage: Add .25 per piece to convert from Standard Mail Postage (Marketing Mail) To First Class Presorted Postage. First Class Postage shortens delivery time by 3 to 5 business days. Note that it also requires special permit and production notes when processing.

Notes: Quantities > 2,500 add \$90 trucking fee (each print run includes 5 unaddressed samples).

CUSTOM GIFT CARD (GC)

Plastic Postcard



POPULAR USES

- Promote Limited Offers
- Loyalty Programs
- Drive Traffic to Boost Sales
- Business Holiday Cards
- Endorse a New Product, Service, or Promotion

USED FOR A VARIETY OF MARKETING CAMPAIGNS:

- New Customer Acquisition
- Customer Retention
- Customer Appreciation
- Membership Drives
- VIP Invitations
- Service Reminders
- Insurance Cards
- Warranty Cards
- Referral Cards

Product Specs

- **Size:** 5.5" x 4.125" flat with credit card pop out, or 5.5" x 4.125" flat with 2 key tag pop outs
- **Layout:** Horizontal or vertical (your choice)
- **Color:** Full color on both sides
- **Paper:** 100 lb. cover stock with an 8 mil. laminate coating

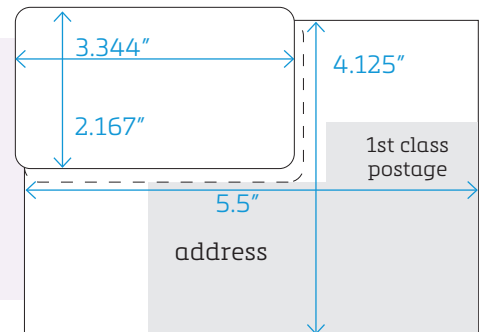

Product	List Type	Minimum Quantity	Cost
5.5" x 4.125" Gift Card - credit card pop out	Saturation	500	\$0.63
5.5" x 4.125" Gift Card - 2 key tag pop out	Saturation	500	\$0.63

Notes: Quarterly Consolidated Mailing

MAIL 2 MOBILE (M2M)



WHAT IS MAIL2MOBILE?

Make print advertising more effective by serving multiple digital impressions to the specific homes you mail to. Capture your best potential customers' attention in multiple media formats, reinforcing your message.

HOW IT WORKS

- 1 We geofence your best prospects' homes
- 2 We send a direct mailer to the same geofenced homes
- 3 We reinforce your mailer with digital ads - before and after it arrives
- 4 We'll track and report on physical visitor conversions

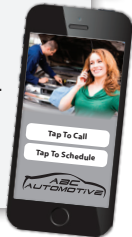

Industry Research has found that Direct Mail results are amplified through complimentary mobile and digital impressions. Mixed campaigns are driving the below impact:



MAIL2MOBILE PROGRAM EXAMPLE

MAKES IT EASY TO DOMINATE YOUR MARKET AREA

Product	List Type	Minimum Quantity	Cost
Mail 2 Mobile	Mailing List	30K up to 100K Impressions	\$0.018

- ✓ Design - consistent messaging for both DM & Mobile
- ✓ Free Call Tracking Number
- ✓ Real Time Analytics Dashboard
- ✓ ROI & Response - amplify traditional results by up to 3x
- ✓ Lead Time - no additional lead time for digital
- ✓ Program Duration - impressions can be pulsed throughout the duration of the promotion
- ✓ Biggest Card in the Industry
- ✓ Weekly Billing / Weekly Mailing
- ✓ Free Trucking

SHARED MAIL (SM)

Marriage Mail | Inserts



Multiple advertisers share the cost of third class mailing by combining their individual printed ads into one open package.

POPULAR USES/BENEFITS

- Coupon Driven
- Promote Special Offers
- Cost Effective
- Target by Zip Code(s)
- Addressed to "Resident" or "Occupant"
- Service Not Available in All Areas
- Average 4-6 Week Turnaround Time
- Weekly, Bi-Weekly & Monthly Distribution (Most Markets)

Product Specs

- **Size:** 8.5"x11"
- **Layout:** Horizontal or vertical (your choice)
- **Color:** Full color on both sides
- **Paper:** 45 lb. coated stock

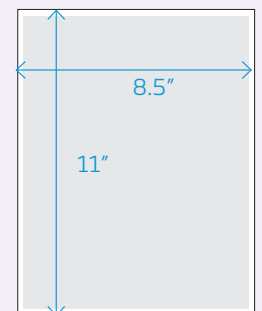

Product	List Type	Minimum Quantity	Cost
Valassis Insert - 8.5 X 11 Value Sheet	N/A	20,000	\$0.12

Notes: Requires 3 to 4 Week Turn Time

8.5 X 11 TRIFOLD ENVELOPE MAILER (LTR)

Letter with Envelope | Standard Letter

POPULAR USES / BENEFITS

- Customizable
- Personalization
- Hand-Written Fonts
- C-Fold & Z-Fold Styles Available
- Official Looking
- Warrants Immediate Attention
- Time-Sensitive Information
- Great for Distributing Important or Private Information
- Can Include Business Reply Envelopes
- Can Include Request for Information
- Great Way to Conduct Surveys
- Great for Advertising to 55+ Age Group

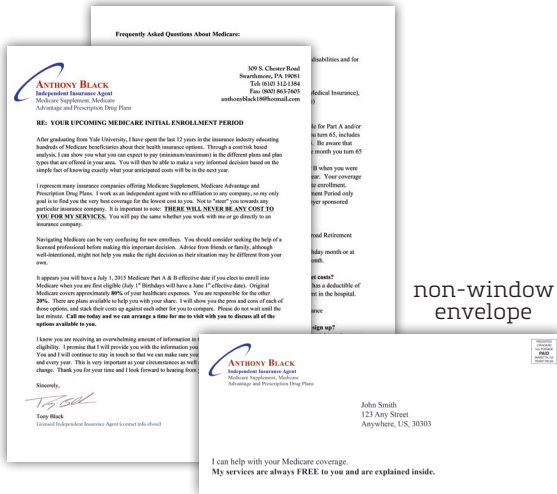

Product Specs

- **Size:** 8.5" x 11" trifold with envelope
- **Layout:** Horizontal or vertical (your choice)
- **Color:** Full color on both sides
- **Paper:** 60 lb. offset
- **Envelope:** Window or non-window available
- **For letters, we must receive content from the customer. Content must be received in a text document (Word.doc, Text.txt, etc.)**

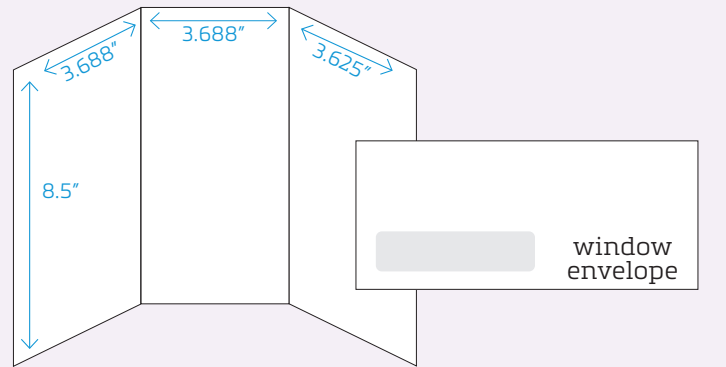

Pricing For Orders under 2,500 Pieces, Add a \$135 Small Quantity Surcharge

*Found under trucking fee.

Product	Neighborhood Mailing	Specialty List Mailing	Ailment List Mailing	State/Regional/National Mailing	Customer Database Mailing
8.5" x 11" (Letter Size)					
8.5x11 Static 1 side Letter in #10 Non Window Envelope	\$0.51	\$0.67	\$0.76	\$0.75	\$0.68
8.5x11 Static 2 side Letter in #10 Non Window Envelope	\$0.53	\$0.68	\$0.77	\$0.76	\$0.70
8.5x11 B&W Variable Data 1 side Letter in #10 Window Envelope	\$0.57	\$0.73	\$0.81	\$0.81	\$0.74
8.5x11 B&W Variable Data 2 side Letter in #10 Window Envelope	\$0.58	\$0.74	\$0.83	\$0.82	\$0.76
8.5x11 Color Variable Data 1 side Letter in #10 Window Envelope	\$0.60	\$0.76	\$0.85	\$0.84	\$0.77
8.5x11 Color Variable Data 2 side Letter in #10 Window Envelope	\$0.62	\$0.79	\$0.87	\$0.87	\$0.79
8.5" x 14" (Legal Size)					
8.5x14 Static 1 side Letter in #10 Non Window Envelope	\$0.54	\$0.70	\$0.79	\$0.78	\$0.71
8.5x14 Static 2 side Letter in #10 Non Window Envelope	\$0.56	\$0.72	\$0.80	\$0.79	\$0.73
8.5x14 B&W Variable Data 1 side Letter in #10 Window Envelope	\$0.60	\$0.76	\$0.85	\$0.84	\$0.77
8.5x14 B&W Variable Data 2 side Letter in #10 Window Envelope	\$0.62	\$0.77	\$0.86	\$0.85	\$0.78
8.5x14 Color Variable Data 1 side Letter in #10 Window Envelope	\$0.63	\$0.79	\$0.87	\$0.87	\$0.80
8.5x14 Color Variable Data 2 side Letter in #10 Window Envelope	\$0.66	\$0.82	\$0.89	\$0.89	\$0.83

Product	Price	Product	Price
Add-Ons			
Static Buckslip (measuring 3.5x8.5 or smaller - 1 Side)	\$0.03	Perforation	\$0.02
Static Buckslip (measuring 3.5x8.5 or smaller - 2 Sides)	\$0.04	Business Reply Envelope (#9, 2/0)	\$0.07
Additional Static Pages (1 Side - price per page)	\$0.08	Additional Static Pages (2 Sides - price per page)	\$0.09
Yellow Bond Paper (for letters only)	\$0.02		

Notes:
 There is a \$135 Small Quantity Fee for orders less than 2,500 pieces.
 Minimum order amount of 250 pieces.

First Class Postage: Add .25 per piece to convert from Standard Mail Postage (Marketing Mail) To First Class Presorted Postage. First Class Postage shortens delivery time by 3 to 5 business days. Note that it also requires special permit and production notes when processing.

M2M & MOBILE ADVERTISING

Target valuable customers that are located around your business, at your competitor's business or maybe old customers – we can locate them and serve up an ad on their smart phone to drive them back to you.

2 MONTH AGREEMENT:	3 MONTH AGREEMENT:
\$800 - 50,000 Impressions/mo (1.6¢ ea)	\$800 - 50,000 Impressions/mo (1.6¢ ea)
\$1,200 - 75,000 Impressions/mo (1.6¢ ea)	\$1,125 - 75,000 Impressions/mo (1.5¢ ea)
\$1,500 - 100,000 Impressions/mo (1.5¢ ea)	\$1,400 - 100,000 Impressions/mo (1.4¢ ea)
\$1,750 - 125,000 Impressions/mo (1.4¢ ea)	\$1,625 - 125,000 Impressions/mo (1.3¢ ea)
\$1,950 - 150,000+ Impressions/mo (1.3¢ ea)	\$1,800 - 150,000+ Impressions/mo (1.2¢ ea)

TARGETED DISPLAY ADS

Use IP addresses of homes or customers around your business to serve up a competitive offer to drive new & existing customers – re-targeting people who have visited your site and stay top of mind to get the sale.

2 MONTH AGREEMENT:	3 MONTH AGREEMENT:
\$750 - 50,000 Impressions/mo (1.5¢ ea)	\$650 - 50,000 Impressions/mo (1.3¢ ea)
\$975 - 75,000 Impressions/mo (1.3¢ ea)	\$825 - 75,000 Impressions/mo (1.1¢ ea)
\$1,200 - 100,000 Impressions/mo (1.2¢ ea)	\$1,000 - 100,000 Impressions/mo (1¢ ea)
\$1,375 - 125,000+ Impressions/mo (1.1¢ ea)	\$1,125 - 125,000+ Impressions/mo (0.9¢ ea)

SOCIAL MEDIA

Market your business on Facebook and target your best customers based on specific variables – also use Facebook to retarget customers that have viewed your website.

MONTHLY PRICING (PER PAGE, 6 MONTH MINIMUM)	BASIC CONTENT \$350	ADS MANAGEMENT \$350	FULL SERVICE \$550
Initial Review & Assessment	✓		✓
Create Professional Cover Photo	✓		✓
Audience Building	✓		✓
4 Non-Branded Facebook Posts Per Week	✓		✓
Basic Profile Management	✓		✓
Deleting Of Unwanted Spam	✓		✓
Responding Back To Posts & Comments	✓		✓
Use Of Hashtags	✓		✓
Monthly Campaign Development (Up To 4 Ads)		✓	✓
Facebook & Instagram Ads Strategy		✓	✓
Facebook & Instagram Ads Placement		✓	✓
Auto-Populated Lead Forms On Facebook, Sent To Your Email		✓	✓
Facebook & Instagram Promoted Post Management		✓	✓
Access To Custom Digital Analytics Dashboard		✓	✓
Includes Monthly 15 Minute Success Call With Social Media Manager		✓	✓



Popular Add-On Boosters:

- Additional Custom Branded Posts - \$25 each
- Additional Ad Creative/Placement - \$50 each
- Additional 15 Minute Social Media Coaching Call - \$50 each
- Setup New Facebook page - \$150 each

**Upgrade to Custom Branded Content:
Additional \$400/Mo**

Save \$100/Month with 12 Month Agreement!

The UpSwell Advantage

BENEFITS

- Dedicated Account Manager
- Superior Customer Service
- Affordable Payment Plan Options
- Full-Service - Design to Delivery
- Variety of Marketing Solutions
- 24 Hour Print to Mail Service*
- Small Business Learning Centers
- In-House Design Staff
- High Quality Commercial Printing
- Quality Assurance for Mail Lists

* 24 Hour Print to Mail Service – Additional Charges Apply

